

# DESIGNING STORMWATER TREATMENT DEVICES – HYDRAULIC CONSIDERATIONS AND IMPLICATIONS

Troy Brockbank<sup>1</sup>, Kevin Jonathan<sup>2</sup>

<sup>1</sup>Design Manager, Stormwater360 New Zealand, Auckland, New Zealand

<sup>2</sup>Stormwater Engineer, Stormwater360 New Zealand, Auckland, New Zealand

---

## Abstract

Stormwater treatment devices are a best management practice that are used to reduce the risk of adverse environmental effects and decrease the contaminant concentrations to below acceptable trigger limits in sensitive receiving environments. The majority of devices in New Zealand tend to be specified and designed according to either Auckland Council's Technical Publication 10, Christchurch City Council's Wetland, Waterways and Drainage Guide or The New Zealand Transport Agency's Stormwater Treatment Standard for State Highway Infrastructure. These documents provide a good general overview of various devices, performance and treatment applications however, the operating effect of the device with regards to the hydraulic grade line is often misinterpreted or unconsidered by designers. Consequently this can lead to under designing the treatment device for the required water quality flows or, at worst, make the device inoperative all together.

Device driving head, tailwater from a downstream receiving waterbody and location of upstream diversion structures are all examples of design considerations that can affect the hydraulic operation of the device. Climate change may also provide future tailwater problems with rising sea levels at coastal outfalls.

This paper will present hydraulic design considerations, beyond the standard guidance information, for stormwater treatment devices and discuss implications on the stormwater network.

## Key Words

Stormwater Treatment Device, Hydraulic Design, Climate Change, Tailwater, Energy Management, Resilience

## Introduction

Urban land development radically alters the hydrological cycle by replacing natural pervious land with vast impervious surfaces. Intensive development in largely urban areas of New Zealand is leading to increased peak stormwater runoff flows and volumes whilst simultaneously reducing the potential for infiltration and evapotranspiration. This development has also lead to an increase in sediment generating activities and subsequent potential of pollutants being carried by runoff as it washes over the land. Polluted runoff can have detrimental effects on the quality of the receiving waterbody.

Regional regulatory authorities, in accordance with the Resource Management Act, have imposed policies requiring land use activities to minimise their adverse environmental effects on water quality, and to avoid, remedy or mitigate the degradation of water by contaminants.

Stormwater treatment devices are a best management practice that are used to reduce the risk of adverse environmental effects and decrease contaminant concentrations to below acceptable trigger limits in sensitive receiving environments.

In order to design a stormwater treatment device for a site, three key parameters need to be considered;

- Flowrate i.e. flow to be discharged to, and treated by the device.
- Contaminant speciation and loading i.e. the target contaminants and sediment load to be treated by the devices treatment mechanism.
- Hydraulics i.e. allowing for sufficient driving head to operate the treatment mechanism.

Treatment and contaminant removal mechanisms will not be discussed in this paper as these parameters are generally well documented and considered by the industry.

This paper will focus on hydraulic design considerations for stormwater treatment devices with the intention of assisting designers to design and evaluate the hydraulic operation of a treatment device in its entirety.

### **Current stormwater treatment device design procedures/guidelines**

The majority of treatment devices in New Zealand are specifically designed according to standard criteria outlined in three guidelines; Technical Publication 10 (Auckland Regional Council, 2003), Waterways, Wetlands & Drainage Guideline (Christchurch City Council, 2003) and Stormwater Treatment Standard for State Highway Infrastructure (New Zealand Transport Agency, 2010).

These documents provide a good general overview of the various device types, their treatment performance capabilities and applications. They tend to be popular with designers due to their ease of use, 'cookbook recipe' design methodology and worked examples. However, these documents lack vital information on the actual operating effect of devices with regards to the hydraulic grade line. Consequently designers can often misinterpret or neglect to give consideration to the hydraulic effects of a treatment device with regards to adjacent nodes/structures within a stormwater reticulation. This can lead to under designing the treatment device for the required peak water quality flows, or in

some worst case scenarios make the device inoperative all together.

### ***Treatment Device Types***

The devices discussed in the standard guidelines mentioned above can be broadly defined as either; volume-based or flow-based.

Volume-based treatment devices are designed to capture, store and treat a water quality volume (WQV). This is acknowledged as the traditional method to size a treatment device. These devices typically rely on low fluid velocities, through a cross-sectional area, and suitable length of flow, i.e. the longer the better, for energy dissipation and sedimentation as the main treatment mechanism. This is typically achieved by restricting the outflow, through a multiple orifice structure, and hence raising the depth of flow. This can create a headwater condition upstream of the device when not considered in the design of the reticulation. Ponds, dry basins and wetlands are examples of volume based devices.

Flow-based treatment devices are designed to capture and treat a water quality flow, and do not require a stored volume of water. These devices typically rely on media filtration or screening, as their treatment mechanism, and require a driving head to achieve specific treatment flow. These devices can be affected by tailwater conditions. Swales, gross pollutant traps (GPT's) and proprietary filtration devices are examples of flow based devices.

Historically, flow-based devices have also been sized to treat a water quality volume. Where a volume has stored to aid treatment and is routed through the device. Two examples are the traditional raingarden & sandfilter. These devices are typically sized according to Darcy's Law (1856), to determine a flow rate through a filter media, and uses a ponding depth above the media to detain and filtrate the water quality volume.

### **Basic Hydraulic Design Principles**

This section outlines the basic fundamentals of hydraulics that have been applied by first principles to the design of hydraulic

structures. These principles are further discussed and referred back to in this paper.

### **Continuity of Flow**

Volumetric flow is defined as volume of fluid which passes a set datum point over a period of time. It can also be calculated as the product of cross-section area for flow and the average flow velocity. It is represented by the Continuity Equation (1);

$$Q = V/t = v * A \quad (1)$$

Where:

Q = Volumetric flowrate (m<sup>3</sup>/s)

V = Volume (m<sup>3</sup>)

t = Time (s)

v = flow velocity (m/s)

A = Cross-sectional area of flow (m<sup>2</sup>)

The law of conservation of mass, as expressed by the continuity equation (1), can be applied to incompressible fluids. It works under the assumption that inflow will equal outflow, regardless of if a fluids velocity or cross-sectional area varies. This is represented by Equation (2);

$$Q_{us} = v_{us} * A_{us} = v_{ds} * A_{ds} = Q_{ds} \quad (2)$$

Where:

us = Upstream

ds = Downstream

### **ENERGY MANAGEMENT**

The underlying principle for hydraulic design of stormwater treatment devices is energy management. Energy is traditionally represented by the term "head", which is defined as the energy per unit weight, and has the units of length (metres). Energy head within a hydraulic structure can be made up from three sub-types;

Velocity Head (Kinetic Energy) = velocity of fluid =  $v^2/2g$  (3)

Pressure Head (Pressure Energy) = depth of fluid =  $Y = P/\gamma$  (4)

Elevation Head (Potential Energy) = elevation of fluid =  $z$  (5)

Where:

v = velocity (m/s)

g = gravitational acceleration (m/s<sup>2</sup>)

P = fluid pressure (Pa)

$\gamma$  = specific weight (N/m<sup>3</sup>)

z = elevation (m)

The total energy head ( $H_E$ ) is the sum of all energy head. It can be represented by a simplified Bernoulli's Principle (Bernoulli, 1738) in Equation (6) and by the Energy Grade Line (EGL) in Figure 1.

$$H_E = v^2/2g + P/\gamma + z \quad (6)$$

The water surface level (h) is the sum of Pressure Head (Y) & Elevation Head (z). It can be represented by Equation (7) and by the Hydraulic Grade Line (HGL) in Figure 1;

$$h = Y + z = P/\gamma + z \quad (7)$$

The law of conservation of energy, as expressed by Bernoulli's Equation, is the basic principle most often used in hydraulic reticulation design. Energy can neither be created nor destroyed; rather, it transforms from one form to another. Hence, the total energy head at any cross-section must equal that in any other downstream section plus the intervening losses. This can be represented by Equation (8) and graphically in Figure 1.

$$v_1^2/2g + P_1/\gamma + z_1 = v_2^2/2g + P_2/\gamma + z_2 + h_f \quad (8)$$

Where:

$h_f$  = head losses (i.e. entry/exit losses or friction) (m)

Rearranging Equation (8) we can determine that the headloss through a hydraulic structure can be represented as upstream minus downstream losses;

$$h_f = ((v_1^2 - v_2^2)/2g) + (P_1/\gamma - P_2/\gamma) + (z_1 - z_2) \quad (9)$$

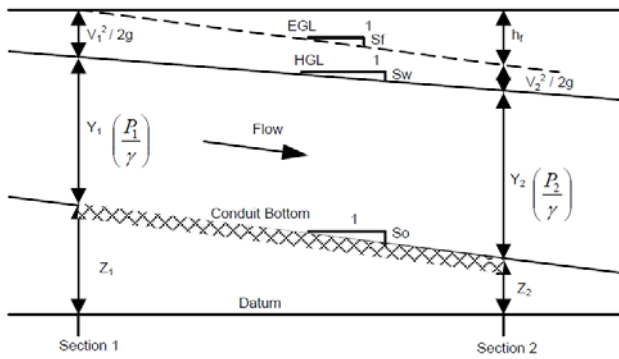

Figure 1: Graphical Representation of Energy Management in a pipe

### Hydraulic Gradient

Hydraulic gradient ( $i$ ) is defined as change in hydraulic head over a change in distance between two points. Simply, it is the slope of the water surface elevation (or more commonly known as the HGL). It is represented by Equation (10).

$$i = dh/dL \text{ (m/m)} \quad (10)$$

The hydraulic gradient can be calculated in either the horizontal or vertical plane as represented Equations (11) & (12) and graphically in Figure 2.

$$i_{\text{Horizontal}} = dh/dL_{\text{Horizontal}} = (h_2 - h_1)/L \quad (11)$$

$$i_{\text{Vertical}} = dh/dL_{\text{Vertical}} = (h_2 - h_1)/(z_2 - z_1) \quad (12)$$

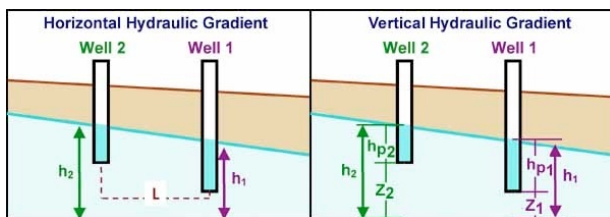

Figure 2: Graphical Representation of Horizontal & Vertical Gradient

### Darcy's Law

Darcy's law is a phenomenologically derived constitutive equation that describes the flow of a fluid through a porous medium (Darcy, 1856). Darcy determined there was a direct relationship between a constant flowrate and the hydraulic gradient (i.e. the elevation drop between two places in a medium and inversely proportional to the distance

between them). This can be represented by the simplified Equation (13) and Figure 3;

$$Q = K * A * i \quad (13)$$

Where:

$Q$  = Flowrate through media ( $m^3/s$ )

$K$  = Hydraulic conductivity of media ( $m/s$ )

$A$  = Cross-sectional area of media ( $m^2$ )

$i$  = Hydraulic Gradient ( $m/m$ )

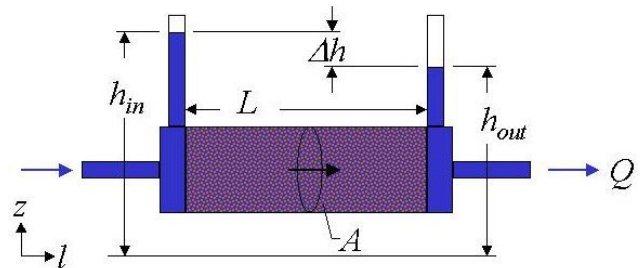

Figure 3: Graphical Representation of Darcy's Law

### Hydraulic Considerations

This section applies the basic hydraulic design principles, as presented above, to the design of stormwater treatment devices. These principles can be applied to both volume-based and flow-based devices to determine the treatment mechanism's operating effect on the hydraulic grade line. Hydraulic considerations, beyond the standard guidance information, are presented and implications on the stormwater network discussed.

### Driving Head

Driving head ( $\Delta h$ ) (also commonly known as hydraulic head) is a measure of the mechanical energy caused by flow. It is defined as the differential of upstream and downstream water surface elevation across a hydraulic structure. This can be represented as equation (14) and graphically in Figure 1.

$$\Delta h = (Y_1 + z_1) - (Y_2 + z_2) = (P_1/\gamma + z_1) - (P_2/\gamma + z_2) \quad (14)$$

For a stormwater treatment device to hydraulically operate properly, sufficient driving head must be available upstream of the device to permit gravity flow of contaminated stormwater through the

treatment mechanism (i.e. filter media) and to discharge treated water downstream.

Not allowing sufficient hydraulic head through the treatment device will reduce the ratio of captured design water quality flow and prematurely bypass untreated sediment laden stormwater. This can also introduce a backwater effect or headwater condition upstream of a treatment device's inlet that will submerge the upstream reticulation, reduce upstream catchpit capacity and, as a worst case scenario, lead to localised upstream flooding.

All treatment devices are hydraulically different i.e. they are designed to treat the same peak flow however, due to their treatment mechanism, will operate at different hydraulic driving heads. For example a traditional sandfilter typically requires 1m of driving head whereas a traditional raingarden requires 0.22m (Auckland Regional Council, 2003).

The treatment mechanism's driving head requirement can be influenced by; internal water depth, media material composition, particle gradation and compaction. The smaller the gradation, higher compaction will require higher driving head to achieve equal flow rate to larger graded material.

Over time, continuous water flow through a filtration device will further compact the media and increase the density of the material. Treatment devices that employ organic materials will need to consider that the material will break down and clog the filter media, even though this mechanism can assist with treatment efficiency, effects to the upstream network from increased hydraulic head need to be considered. Hence, the driving head required to achieve the designed flow rate will increase.

As a treatment device removes contaminants from stormwater, the trapped contaminants increase the filter media density and reduces available voids. Without periodical maintenance, the required driving head to achieve the designed flow rate will increase and can allow untreated sediment laden stormwater to bypass the device prematurely.

### **Physical drop**

The physical drop ( $\Delta z$ ) (also commonly known as Elevation head) is defined as the differential of inlet and outlet inverts across a hydraulic structure. It can be represented as equation (15) and graphically in Figure 1.

$$\Delta z = (z_1 - z_2) \quad (15)$$

The physical drop of pipe inverts is commonly misrepresented by designers to be the **total driving head** required to operate a treatment device. In fact the physical drop is only a part of the total driving head as represented by  $z$  in Equation (7).

This misinterpretation will lead to underestimating the actual available hydraulic head in the upstream reticulation design. Hence the water surface level (HGL) may actually be at a higher reduced level, than originally calculated, and at a steeper hydraulic gradient (i). This will result in surcharging the upstream network (i.e. headwater) during low flows as a consequence of a higher flow depth. Additional head losses due to friction, and upstream structures entry/exit losses may also occur. Localised flooding of the upstream catchment and increased overland flows, where sump inlet capacity has been reduced, can consequently occur as worse case scenarios where this headwater condition has not been factored into the reticulation design.

The relationship between driving head and the physical drop can be further explained in the hydraulic operation of an upward flowing proprietary device (Figure 4 & Figure 5), as verified by the New Jersey Corporation for Advanced Technology (NJCAT) (2008; 2015). The physical drop ( $\Delta z$ ) between inlet and outlet pipe inverts is shown as 240mm, whereas the driving head ( $\Delta h$ ) at maximum treatment peak flow is shown as 750mm between the outlet invert and the internal bypass weir invert (Figure 4). This configuration will result in a minimum 510mm ( $\Delta h - \Delta z$ ) surcharging headwater condition upstream of the inlet pipe. The hydraulic head of the device will be further increased to 790mm as bypass flow discharges through the siphon-activated bypass (Figure 5).

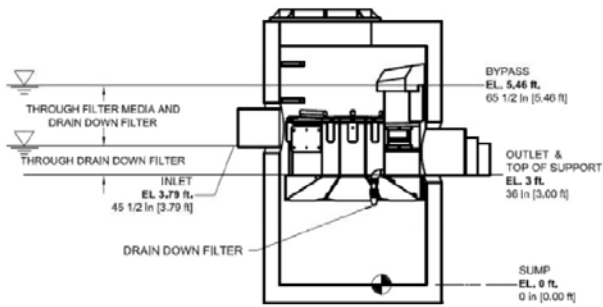

Figure 4: Physical Drop representation in an upward flowing proprietary treatment device

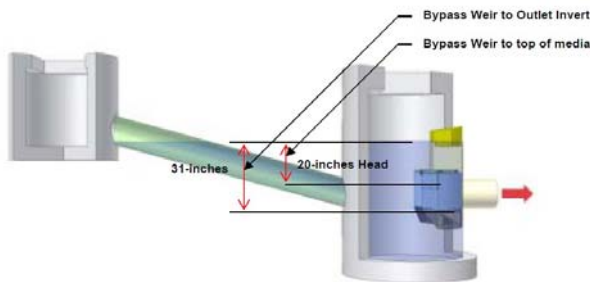

Figure 5: Driving Head representation in an upward flowing proprietary treatment device

It is recommended, if site constraints allow, to set the physical drop between inlet and outlet inverts at the same reduced level as the total hydraulic head in order to prevent unnecessary surcharge and headwater conditions as mentioned above. If this is not possible, it is recommended to design the upstream pipe network for the anticipated headwater condition.

### Filtration media sizing

A standardised filtration media sizing formula is commonly used to determine the required filter footprint ( $A_f$ ) in a traditional filtration type treatment device, i.e. Sandfilter or Raingarden, to treat a water quality volume. (ARC, 2003; Shaver & Clode, 2009; NZTA, 2010; Christensen & Couling, 2014). This standardised filtration sizing formula is represented by Equation (16);

$$A_f = (WQV \cdot d_f) / (k \cdot (h + d_f) \cdot t_f) \quad (16)$$

Where:

$A_f$  = Surface Area of filter media ( $m^2$ )

WQV = Water Quality Volume ( $m^3$ )

$t_f$  = time required for runoff to drain through the filter media (day)

$k$  = Co-efficient of permeability (m/day)

$d_f$  = Media depth (m)

$h$  = mean ponding depth above filter media (m)

This standardised filtration sizing formula is derived from Darcy's Law using a vertical hydraulic gradient. This is shown in Equation (17) by interchanging variables from Equation (16) into Equation (13);

$$Q = k \cdot A \cdot i = WQV/t_f = k \cdot A_f \cdot (h + d_f)/d_f \quad (17)$$

Where:

$i = i_{\text{vertical}}$  = hydraulic gradient of mean

ponding depth =  $dh/dL_{\text{vertical}} = (h + d_f)/d_f$  (m/m)

### Unsaturated media zone

The standardised filtration media sizing formula (Equation 16) is intended to be used for unsaturated filtration media configurations (i.e. without a saturated or internal water storage zone (IWS) encroaching into the media) with discharge from a conventional outlet pipe located beneath the bottom of the media (Figure 6).

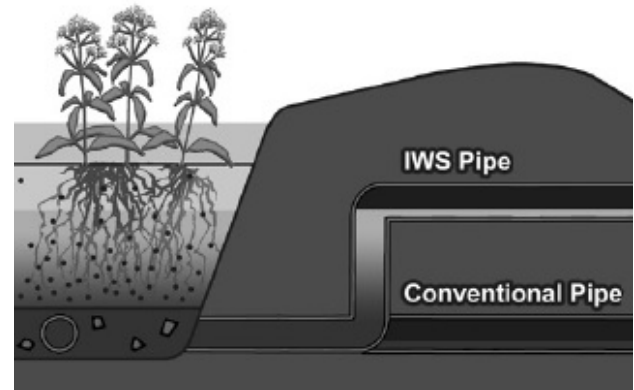

Figure 6: Raised (Internal Water Storage) vs Conventional Outlet Pipes

### Internal water storage / saturated media zone

A submerged or internal water storage (IWS) zone occurs when the outlet downstream of a treatment device is raised i.e. via an upturned 90° elbow bend (Figure 6). The IWS zone is recommended to be situated below the bottom of the filtration media (i.e. unsaturated media) (FAWB, 2009; NZTA, 2010). Where this is the case, it is recommended to use

Equation (16) to size an appropriate treatment device.

However, there are situations where it is necessary to have an IWS zone within the media (i.e. saturated media) due to site constraints and existing outfall inverts. An example of this saturated scenario can be found in Christchurch where a submerged zone, with the top of the submerged zone located a minimum of 0.3 m below the media surface, has been recommended as a standard raingarden design practice to allow for connection to the network (or discharge) at a depth of 0.6 m below the ground surface (depth to IL) (Christensen & Couling, 2014).

This raised outlet invert configuration will reduce the available hydraulic head ( $\Delta h$ ) and gradient ( $i$ ) as shown by the water surface profile in Figure 6. This means the maximum flowrate through the media will also reduce as it is proportional to the hydraulic gradient

( $Q \propto i$ ) (Darcy, 1856). For example, using

Christchurch City Council's submerged zone raingarden standard design practice, a 50% reduction in the hydraulic head ( $\Delta h$ ) will proportionally equal a 50% reduction in the treatable flowrate. This effectively means the footprint of the submerged zone rain garden would need to be at least double the size of an unsubmerged zone rain garden to treat the same flow.

The use of the standardised filtration media sizing formula for this saturated media scenario will result in under sizing the device for the intended water quality volume and flows. This can allow untreated sediment laden stormwater to bypass the device prematurely. Hence, in order to size a filtration device with an IWS zone that encroaches on the filter media it is recommended to substitute the revised hydraulic gradient, as represented by Equation (18), into the standardised filtration media sizing formula (Equation 16). This modified saturated media IWS zone sizing equation is represented by Equation (19);

$$i = i_{\text{Vertical}} = \frac{dh}{dL_{\text{Vertical}}} = \frac{(h_2 - h_1)}{(z_2 - z_1)} = \frac{((h+d_f)-d_{\text{IWS}})}{(d_f-0)} \text{ (m/m)} \quad (18)$$

$$A_f = (WQV \cdot d_f) / (k \cdot (h+d_f-d_{\text{IWS}}) \cdot t_f) \text{ (m}^2\text{)} \quad (19)$$

Where:

$A_f$  = Surface Area of filter media ( $\text{m}^2$ )

WQV = Water Quality Volume ( $\text{m}^3$ )

$t_f$  = time required for runoff to drain through the filter media (day)

$k$  = Co-efficient of permeability (m/day)

$d_f$  = Media depth (m)

$h$  = mean ponding depth above filter media (m)

$d_{\text{IWS}}$  = Depth of filter media encroached by the IWS zone (m)

$i$  = hydraulic gradient (m/m)

### **Headwater**

Headwater (also commonly known as backwater) is defined as the water surface elevation located upstream of a hydraulic structure (Buchanan, et al., 2013). This condition typically occurs as a result of a downstream obstruction/restriction that raises the depth of flow. Using the continuity equation (1), as the depth of flow increases, the cross-sectional area of flow will increase and hence the velocity must decrease to maintain the same flow. This increase in flow depth can be due to a bypass weir structure, treatment mechanism (i.e. filter media) & associated driving head, or reducing the flow cross-sectional area (i.e. orifice).

Headwater is also typically promoted in volume-based treatment devices (i.e. ponds, wetlands etc.) and flow-based hydrodynamic separators which rely on low fluid velocities for energy dissipation and sedimentation as the main treatment mechanism. There is a relationship between the velocity and treatment efficiency i.e. the lower the velocity, the greater potential for particles to settle, and hence the greater the treatment efficiency. Decreasing the velocity can also prevent scour and reduce re-suspension of collected contaminants.

An example of a backwater condition is shown by the water surface profile through a proprietary hydrodynamic separator (Figure 7). As water flows through the device headloss causes the water surface elevation to rise. The low flow control orifice creates a

backwater at peak conditions to act as a brake on incoming water. This reduces velocity and turbulence throughout the system, which prevents re-suspension of sediment while also elevating floatables above both the inlet and the bottom of the baffle. This reduced velocity also increases the flow path in the swirl chamber for greater sedimentation efficiency.

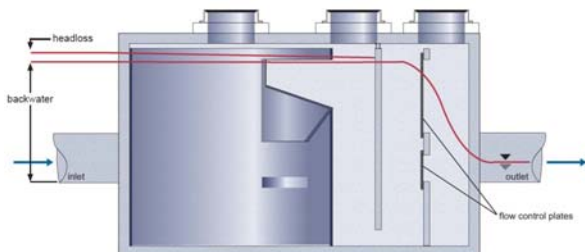

Figure 7: Water surface elevation through a proprietary hydrodynamic separator

Hence, it is essential that headwater is accounted for in the design of upstream reticulations to prevent unintended submerged pipe conditions, reductions in flow capacity and localised flooding due to a raised HGL.

### Tailwater

Tailwater is defined as the water surface elevation located downstream of a hydraulic structure (Buchanan, et al., 2013).

There are two distinctive types of tailwater; permanent & operating. Permanent tailwater occurs when there is a permanent pool or water surface downstream of a treatment device. This can be due to a static water level in a natural waterbody (i.e. wetland/pond, stream/river or ocean etc.) or a man-made structure (i.e. bubble up chamber, submerged pipe network etc.). When the downstream waterbody is affected by tidal fluctuations it is recommended that the mean high waters spring (MHWS) or greater reduced level (RL) be used as the permanent tailwater level.

Operating tailwater is the dynamic water level due to fluctuating outflow depth i.e. as flow increases, the depth of flow increases. This can occur as a result of direct outflow from a treatment device (i.e. flow in outlet pipe) or indirectly via flows in a downstream reticulation/waterbody (i.e. 100-year peak

flows in main trunk pipeline from the upper catchment).

Tailwater is an important design consideration for locating a treatment device within a stormwater reticulation network. It has the potential to directly affect the hydraulic driving head ( $\Delta h$ ), peak treatable flow rate, and operating mechanism of a treatment device. It can also affect the position of an upstream peak flow diversion structure.

Setting the outlet invert of a treatment device, below the permanent tailwater elevation can create a saturated zone in a treatment device. This will reduce the hydraulic driving head ( $\Delta h$ ) of the treatment mechanism and can introduce biofouling to wetted surfaces with the device. In the case of filtration devices (i.e. sandfilter & raingardens) this has the potential to prematurely clog the treatment mechanism. A reduction in hydraulic head will also require extending the treatment device footprint to maintain the same flow (Darcy, 1856).

It is recommended to set the outlet invert of the treatment device at the known permanent tailwater as a standard design practice. For low hydraulic head sites, the outlet invert of the treatment mechanism, i.e. bottom of filter media, at the maximum operating tailwater elevation.

An example of where to set the outlet invert in a treatment device, with regards to tailwater elevation, can be shown via the hydraulic operation of a proprietary membrane cartridge filter (Figure 8). This device includes a backwash pool weir which allows the system to passively backwash the cartridges installed within the weir each time a storm event subsides. Evaluating the tailwater condition against the backwash pool weir elevation allows for determination of proper function, and can aid in determining the elevation of a bypass weir in an upstream diversion structure. The ideal scenario is to set the tailwater condition at or below the outlet invert to ensure the device operates as intended with no special design considerations. If the tailwater condition is located at or above the outlet invert, but below the elevation of the deck's backwash pool weir, the passive backwash operation



may be impacted. If the tailwater condition is located above the elevation of the backwash pool weir, the backwash operation and net available hydraulic driving head ( $\Delta h$ ) of the device will be impacted, as it will have to work against the standing water column during treatment and backwashing operation (Kahlenberg, 2015).

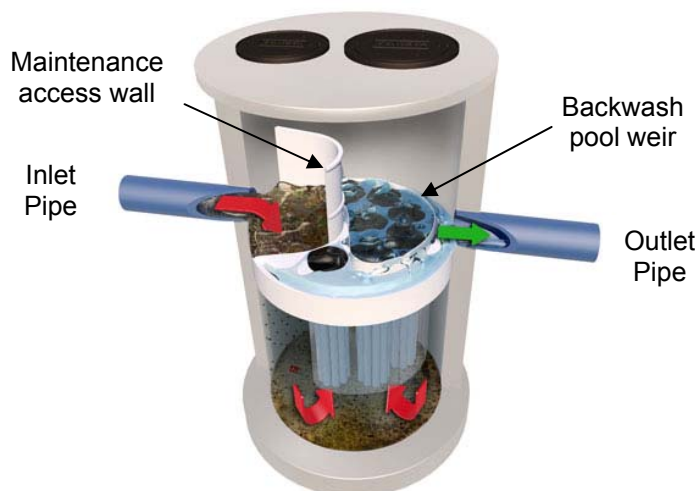

Figure 8: Standard configuration of a proprietary membrane cartridge filter

### Online vs Offline Configuration

Stormwater treatment devices can be installed in either an online or offline peak flow configuration. An online configuration is when a device is installed on main trunk line and the total peak flow discharge through the device. An offline configuration is when peak flowrates are bypassed around the device and only the water quality flow is discharged through the device. This can be achieved either internally or externally via a diversion structure (i.e. flow splitting weir).

Historically, the majority of stormwater treatment devices have been installed in an online configuration. This tends to result in peaks flows, in excess of the water quality treatment flows, scouring and re-suspending the collected material within a treatment device. These larger peak flows can also lead to damage of hydraulic structures and treatment mechanisms.

Hence it is now preferred to install devices in an offline configuration and often enforced by local jurisdictions.

### Peak flow bypass structure

A peak flow bypass structure is a hydraulic structure typically used in offline configurations. It is installed upstream of a treatment device to split and divert flows higher than water quality flow around a treatment device.

The peak flow bypass structure typically consists of a diversion weir within a manhole/vault and installed on a main trunk pipeline. Stormwater runoff flows into the bypass structure where the low water quality, and first flush, flows are diverted by the weir to a treatment device through a branch pipe line. The larger peak flows discharge over the weir to the main trunk pipeline. A multiple high-flow/low-flow orifice type bypass structure can also be used. However, it is not recommended as the hydraulic operation of this type of structure can be complex and tends to increase the headwater condition if misinterpreted.

Peak flowrates higher than the design water quality flow can create additional headwater in the upstream reticulation due to the depth of flow required to discharge over the weir. To overcome this problem, the length of the weir can be increased and revised flowrates calculated using a standard weir flow formula.

It is recommended to design the peak bypass structure in tandem with the hydraulic design of downstream treatment devices. It is preferred to set the 'top of weir' invert at the same elevation as the maximum anticipated headwater elevation required by the operation of the treatment mechanism in the treatment device. This will ensure all design water quality flow is captured and directed to the treatment device.

The headwater condition created by peak flows, discharging through the bypass structure, is required to be evaluated against the hydraulic grade line of the reticulation to ensure there are no adverse upstream effects.

### Discussion

Designing and building resilience into urban stormwater reticulations is recognized as being important to minimise flooding impacts and consequences under uncertain future

climate change and urbanisation conditions (Mugume, et al., 2014). Disregarding the concept of resilience could lead to scenario where a catchment is less likely to bounce back or introduce significant damage to site and infrastructure.

Hydraulic design of treatment devices aligns with the concept of resilience. Underestimating treatment device hydraulic effects can cause an adverse effect to the upstream network such as reduced flow capacity, localised flooding and increased overland flows, as outlined through this paper.

In order to be a truly resilient design it is necessary to future proof treatment devices by considering and allowing for the potential effects from climate change and intensification.

### **Future Growth**

Urban intensification is an unavoidable reaction to an increasing population, which brings with it an increased population density, and consequently an increase in the number and volume of vehicles using urban roads. As such road lanes are increasing, green space is turned to grey development and, pervious areas are developed to impervious surfaces. Therefore considering design resilience to incorporate the demands of future growth is crucial to preventing costly upgrades to hydraulic structures or stormwater treatment devices over their life span.

With increases to population density and daily traffic averages, contaminant concentration will likely increase; this will need to be taken into consideration when designing a treatment device. Alternatively extending the original treatment device or installing a new connection parallel to the original treatment device to mitigate these factors could be an option, however this will be a costly exercise.

In many cases for commercial and industrial development, original pervious areas such as gardens or metal/gravel areas will eventually be converted to carpark extensions, building extension or asphalt areas for storage. The increase of impervious areas will increase water quality flow to be treated by the

treatment device. An allowance, factored in at the design stage, to allow for the extension of the treatment device for these future growth needs will prevent costly in-situ solution later on.

### **Climate Change**

Climate change is a change in average statistical weather patterns over an extended period of time. Observations and scientific models have observed; higher intensity rainfall over shorter periods of time, droughts occurring over longer periods of time increased atmospheric average temperature and a rise in sea levels (MfE, 2008).

Climate change plays a crucial role in the design of treatment devices due to the foreseen changes in hydraulic head and peak flowrates.

An increased rainfall intensity and annual exceedance probability (AEP) will lead to a more frequent and larger peak flow rate discharging to a treatment device. This will increase fluid velocities and can lead to a reduction in the performance efficiency of treatment mechanisms. This also enforces the need to design the treatment devices offline to bypass the larger peak flows, whilst future proofing for increased flowrates as a result of climate change, to prevent scour, re-suspension of collected contaminants and damage to hydraulic structures or treatment mechanisms.

Treatment devices employing plants as part of its treatment mechanism, i.e. swale, wetland or raingarden, may also be affected by longer period of droughts. Specifying species of plant that can survive long periods of drought or inclusion of an internal water storage (IWS) will be crucial to these devices (FAWB, 2009).

Rising sea levels will lead to increased tailwater conditions and can affect treatment devices installed close to tidal waterbodies or reaches. This can cause a reduction in hydraulic head ( $\Delta h$ ) through the device and reduce the hydraulic operation as mentioned above. It is recommended to futureproof treatment devices for this foreseen sea level rise and locate the outlet invert at a higher level. The Ministry for the Environment has

produced recommended baseline sea-level rise values that can be used for this purpose (King, 2009).

## **Conclusions**

Stormwater treatment devices within New Zealand are typically designed using a 'cookbook recipe' method from the three standard stormwater guidelines. These guidelines provide an excellent resource with regards to treatment device performance and hydrological design. However, vital instruction on the hydraulic design of treatment devices and the operational effects on their treatment mechanism within these documents is minimal. This can lead to misinterpretation or neglect to the hydraulic effects of a treatment device with regards to adjacent nodes/structures within a stormwater reticulation.

Consequently, this can result in under designing the treatment device for the required peak water quality flows, or in some worst case scenarios make the device inoperative all together.

By not considering or misunderstanding the available information, with regards to the hydraulic grade line, treatment devices risk unintentionally adversely affecting not only the upstream (giving) environment, but also the downstream (receiving) environment. As outlined throughout this paper, the implications can include; flooding as a result of un-factored headwater/tailwater conditions, untreated sediment laden stormwater to prematurely bypass the device and under sizing the device for its intended treatable flow. Therefore hydraulics is an important consideration for resilient design.

The workings and design suggestions outlined in this paper are intended to assist designers to design and evaluate the hydraulic operation of a treatment device in its entirety. This paper can be used in conjunction with existing standard guidelines until such a time as these standard documents are revised to include advanced hydraulic considerations.

## References

ARC, 2003. *Technical publication 10: Stormwater management devices - Design guidelines manual*. 2nd ed. Auckland: Auckland Regional Council.

Auckland Council, 2013. *TR2013/035; Auckland Unitary Plan stormwater management provisions: Technical basis of contaminant and volume management requirements*, Auckland: Auckland Council.

Bernoulli, D., 1738. *Hydrodynamica sive de viribus et motibus fluidorum commentarii*. Strassburg: Johann Reinhold Dulsecker.

Buchanan, K., Clarke, C. & Voyde, E., 2013. *TR2013/018: Hydraulic energy management: inlet and outlet design for treatment devices*, Auckland: Auckland Council.

CCC, 2003. *Waterways, wetlands and drainage guide*. Christchurch: Christchurch City Council.

Christensen, P. & Couling, K., 2014. *Christchurch Rain Garden Design Criteria*. Christchurch: Christchurch City Council.

Darcy, H., 1856. *Les Fontaines publiques de la ville de Dijon*. Paris: Victor Dalmont.

FAWB, 2009. *Adoption Guidelines for Stormwater Biofiltration Systems*. Melbourne: Facility for Advancing Water Biofiltration, Monash University.

Kahlenberg, J., 2015. *Stormwater filtration: a tail(water)-end discussion*. [Online] Available at:

<http://www.imbriumsystems.com/Dropzone-Newsletter/ID/42>  
[Accessed 14 03 2016].

King, J., 2009. *Preparing for coastal change: A guide for local government in New Zealand*, Wellington: Ministry for the Environment.

MfE, 2008. *Climate Change Effects and Impacts Assessment: A Guidance Manual for Local Government in New Zealand*. 2nd ed. Wellington: Ministry for the Environment.

Mugume, S., Gomez, D. & Butler, D., 2014. *Quantifying the Resilience of Urban Drainage Systems Using a Hydraulic Performance Assessment Approach*. Sarawak, IAHR (International Association for Hydro-Environment) / IWA (International Water Association).

NJCAT, 2008. *Technology Verification: Up-Flo Filter*, Hoboken: New Jersey Corporation for Advanced Technology.

NJCAT, 2015. *Technology Verification: Up-Flo Filter*, Hoboken: New Jersey Corporation for Advanced Technology.

NZTA, 2010. *Stormwater Treatment Standard for State Highway Infrastructure*. Wellington: New Zealand Transport Agency.

Shaver, E. & Clode, G., 2009. *Hawke's Bay Waterway Guidelines: Stormwater Management*. Napier: Hawke's Bay Regional Council.

## Presenter profile

Troy Brockbank is a qualified civil engineer with Stormwater360 New Zealand. He has over nine years professional experience in the stormwater industry and has developed specialist skills in designing and constructing stormwater management devices. You may contact him at [Troyb@stormwater360.co.nz](mailto:Troyb@stormwater360.co.nz) or at PO Box 302 890, North Harbour, Auckland 0751, New Zealand.

Kevin Jonathan is a stormwater engineer with Stormwater360 New Zealand. He is an integral member of the design team and heavily involved in the design of stormwater treatment devices. You may contact him at [Kevinj@stormwater360.co.nz](mailto:Kevinj@stormwater360.co.nz) or at PO Box 302 890, North Harbour, Auckland 0751, New Zealand.